

BULLETIN 2000-015-BU/EL

Revised October 5, 2015

EMERGENCY GENERATOR ROOMS

The intent of this bulletin is to provide clarification and to establish a consistent and uniform enforcement approach for the installation requirements of the generating set and equipment related to the emergency power supply system contained by the emergency generator service rooms.

BACKGROUND

Sentence 3.2.7.5.(1) of the Vancouver Building By-law (VBBL) requires emergency generator sets to be installed in conformance with CSA C282, "Emergency Electrical Power Supply for Buildings". Sentence 3.6.2.8.(1) "Emergency Power Installations" requires an emergency generator located in a building except where such building is used solely for the purpose of housing the generator and its ancillary equipment must be located in a room that is separated from the remainder of the building by a fire separation having a fire-resistance rating not less than 2 h and contains only the generating set and equipment related to the emergency power supply system.

Situations have been encountered where the location of the emergency generator is not shown on the building permit drawings. This may cause problems at the electrical permit submission stage and has often resulted in the electrical designer having to attempt to shoe-horn the generator set into an inadequate space. To avoid such problems, designers are requested to show the location of the emergency generator room on the building permit drawings and fully coordinate the installation with electrical, mechanical and structural disciplines. Also, situations have been encountered that emergency generator rooms are designed to contain other electrical equipment for which these rooms are not intended. Sentence 3.6.2.8.(1) of Division B of the VBBL requires emergency generator room contains only the generating set and equipment related to the emergency power supply system. CSA C282 requires that emergency generators in a building must be located in separate service room(s) used solely for the generator sets and all auxiliary equipment. However, some designers and installers interpret "equipment" that is allowed to be installed in these rooms as any electrical equipment supplied by the emergency generator that includes life safety and non-life safety loads supplied by equipment.

In certain circumstances, it may be desirable to install the generator set in a prefabricated metal enclosure outside the building envelope. This may be done provided; the location is accepted by the City during the development permit process, the generator set is installed in conformance with Article 3.6.1.4. of Division B the VBBL and it is afforded the same level of protection from fire, the environment and vandalism as would be obtained in a fire-separated room in the building. Specifically, the following items should be addressed:

- The enclosure shall be fire or spatially-separated from adjacent buildings and the building it serves.
- The enclosure shall be structurally adequate to resist flood, snow, wind, and shall be vandal-proof.
- The enclosure shall be braced for seismic forces where required by the VBBL.

- The enclosure shall be weatherproof and insulated to achieve the ambient temperature requirement of CSA C282 to maintain the system in an operable condition and prevent problems due to condensation and corrosion.
- The enclosure shall provide adequate clearances as specified in CSA C282.
- The generator set and batteries shall be heated as required to ensure reliable start-up under adverse climatic conditions.
- The enclosure and generator set shall be protected from flooding, the intake and exhaust ducts shall be appropriately located to protect against drifting snow.
- Satisfactory precautions shall be taken to control noise and exhaust emissions.

REQUIREMENTS

Sentence 3.6.2.8.(1) of Division B of the VBBL requires emergency generator room contains only the generating set and equipment related to the emergency power supply system. CSA C282 requires that emergency generators in a building must be located in separate service room(s) used solely for the generator sets and all auxiliary equipment, such service room(s) must be separated from the remainder of the building by a fire separation. Auxiliary equipment means all supplementary apparatus and devices necessary for starting and operating an emergency electrical power supply. It is expected that the emergency generator service room will contain all of the elements essential to the reliable production and delivery of that power (e.g., the engine, generator, fuel supply, starting batteries, instrumentation, switchgear, combustion and cooling air supply damper control motors). Service room for the emergency power supply system installation is required to ensure the reliable production and delivery of electrical power to critical emergency circuits for a specified period of time when the supply authority power is lost. It is also expected that access to the emergency generator room will be restricted to authorized personnel. See example of the attachment in respect of the emergency generator room layout and diagram for equipment related to the emergency power supply system.

(Original signed by)

W. White
Deputy City Electrician
Manager, Trades Inspection

(Original signed by)

P. Ryan, M.Sc., P.Eng.
Chief Building Official
Director, Building Code and Policy

Attachment

EMERGENCY GENERATOR ROOMS

Example of EM generator room layout and diagram for equipment related to EM power supply system

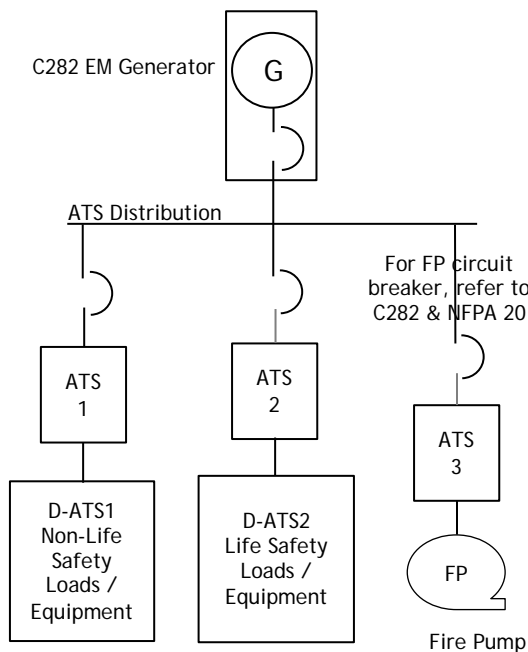
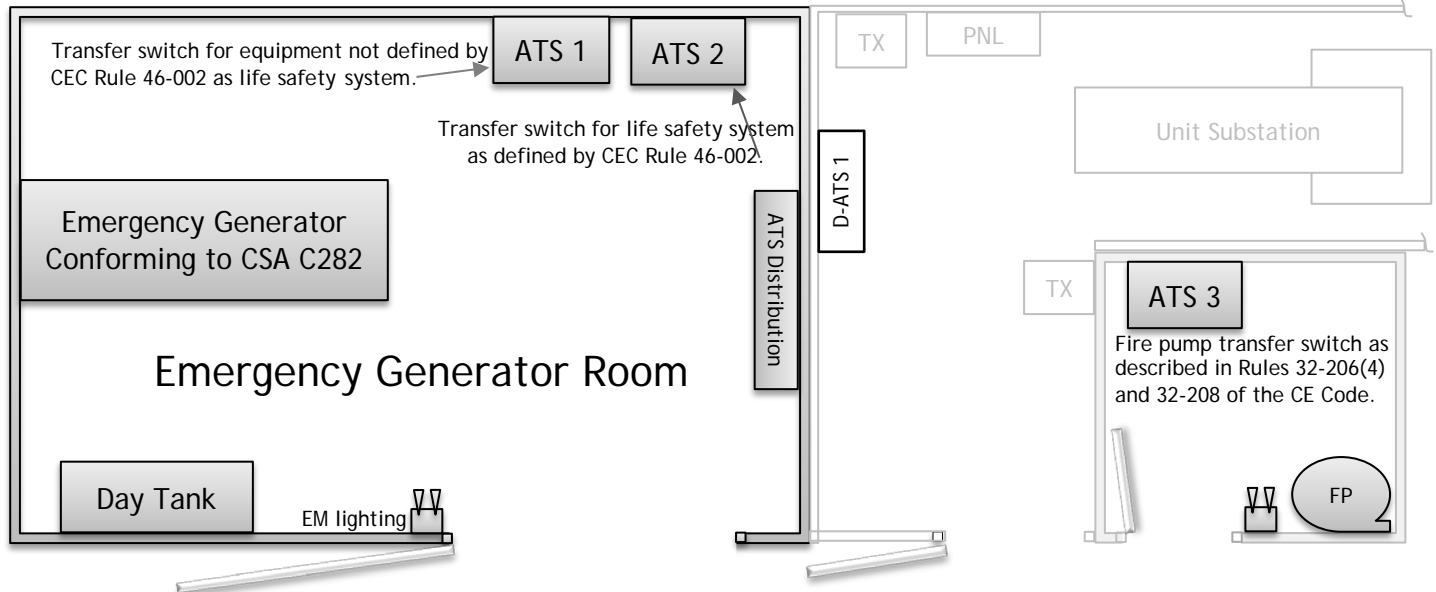

Diagram

Notes:

- In accordance with the C282, the emergency electrical power supply system shall consist of all of the equipment and systems necessary to supply reliable electrical power, including the following:
 - a) the engine generator set, which can include an auxiliary supply tank;
 - b) the fuel supply system, including tanks and piping as described in Clause 7.3;
 - c) automatic transfer switches and all associated wiring;
 - d) the emergency generator ventilation and cooling system;
 - e) wiring and all electrical components between an emergency generator and the emergency supply terminals of transfer switches specified in Clause 9; and
 - f) the exhaust silencer and piping to outdoors.
- Protection of electrical conductors must meet the applicable requirements of Article 3.2.7.10 of Division B of the VBBL.